

Messrs.:

3TNV82A-DSA2

for Utility

SPECIFICATIONS & DRAWINGS FOR MASS PRODUCTION

19.Feb.2004



YANMAR CO., LTD.

ENGINE SPECIFICATIONS

G3-19802-0060

No	Model name	3TNV82A-DSA2		Remarks	
1	Type	4 cycle, Inline, Water-cooled Diesel			
2	No. of cylinders-Bore×Stroke	mm	3-φ82×84		
3	Combustion system	Direct Injection			
4	Compression ratio	19.2			
5	Displacement	litter	1.331		
6	Rated output	kW(PS)	22.5(30.6)		
		min ⁻¹	3000		
7	Gross output	kW(PS)	23(31.3)		
		min ⁻¹	3000		
8	Max. torque	N·m	79.4~86.3		
		min ⁻¹	1800(+100/-100)		
9	Specific fuel consumption	g/kW-h(g/PS-h)	262(193)	at rated output	
10	Ambient condition	25°C、750mmHg、30%			
11	Engine speed at no load	Max.	min ⁻¹ 3180	+25/-25	
		Min.	min ⁻¹ 1000	+25/-25	
12	Governorability	Governor type	centrifugal-all speed governor		
		Temporary	%	max.12	load 100% ↓ 0%
		Permanent	%	max.6	
		Recovery time	sec	max.6	
		Stability	rev	max.22	
13	Gradients	Longitudinal	deg 30(25)	intermitted () : continuous	
		Lateral	deg 30(25)		
14	Firing order	1-3-2-1		order from F.W.	
15	Direction of rotation	counterclockwise		viewed from F.W.	
16	Engine dry weight	kg	approx.128		
17	Fuel injection timing	deg	FIR4.0° / FIT16.5°	b.T.D.C	
18	Fuel system	Fuel type	Diesel oil		
		Fuel injection pump	Distributortype(YPD-MP2), Yanmar made		
		Fuel injection nozzle	hole type		
		Fuel filter	paper element		
19	Lubrication system	System	forced feed		
		Oil grade	SAE class CD, IPE grade 10W30		
		Oil pump	trochoid pump		
		Oil filter	paper element		
		Oil capacity	litter	5.5	max.
			litter	1.9	effective.
		Oil pressure	kgf/cm ²	4.5	at rated output
			kgf/cm ²	1	at low idle
20	Cooling system	Heat exchanger	none		
		Pressure cap	kgf/cm ²	0.9	
		Fan	5-φ335		
		Coolant capacity	litter	1.8	

3TNV82A-DSA2

ENGINE SPECIFICATIONS

G3-19802-0060

No	Model name	3TNV82A-DSA2	Remarks
21	Air cleaner		
22	Breather system		
23	Muffler		
24	Starting system	Starter	12V-1.7kW
		Battery	80D26
		Starting aid	air heater 400W
25	Generator	12V-40A	
26	Engine color	Silver	
27	Applied regulation	ARB-OR2 EC(NRMM) EPA Tier2	

<Carrier>

Messrs: YA	W.No.	3TNV82A-DSA2
------------	-------	--------------

3TNV82A-DSA2

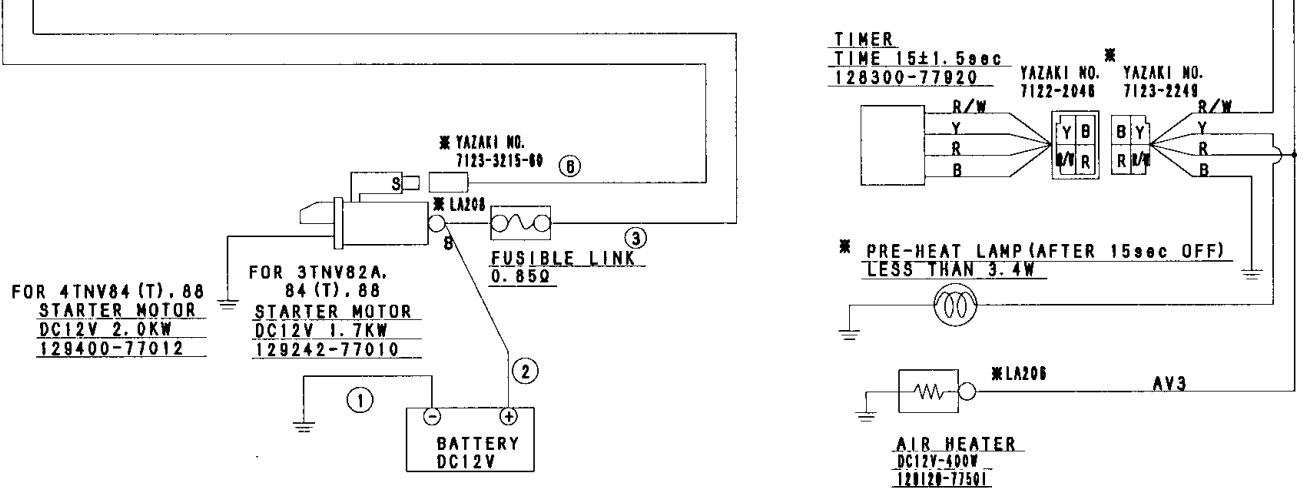
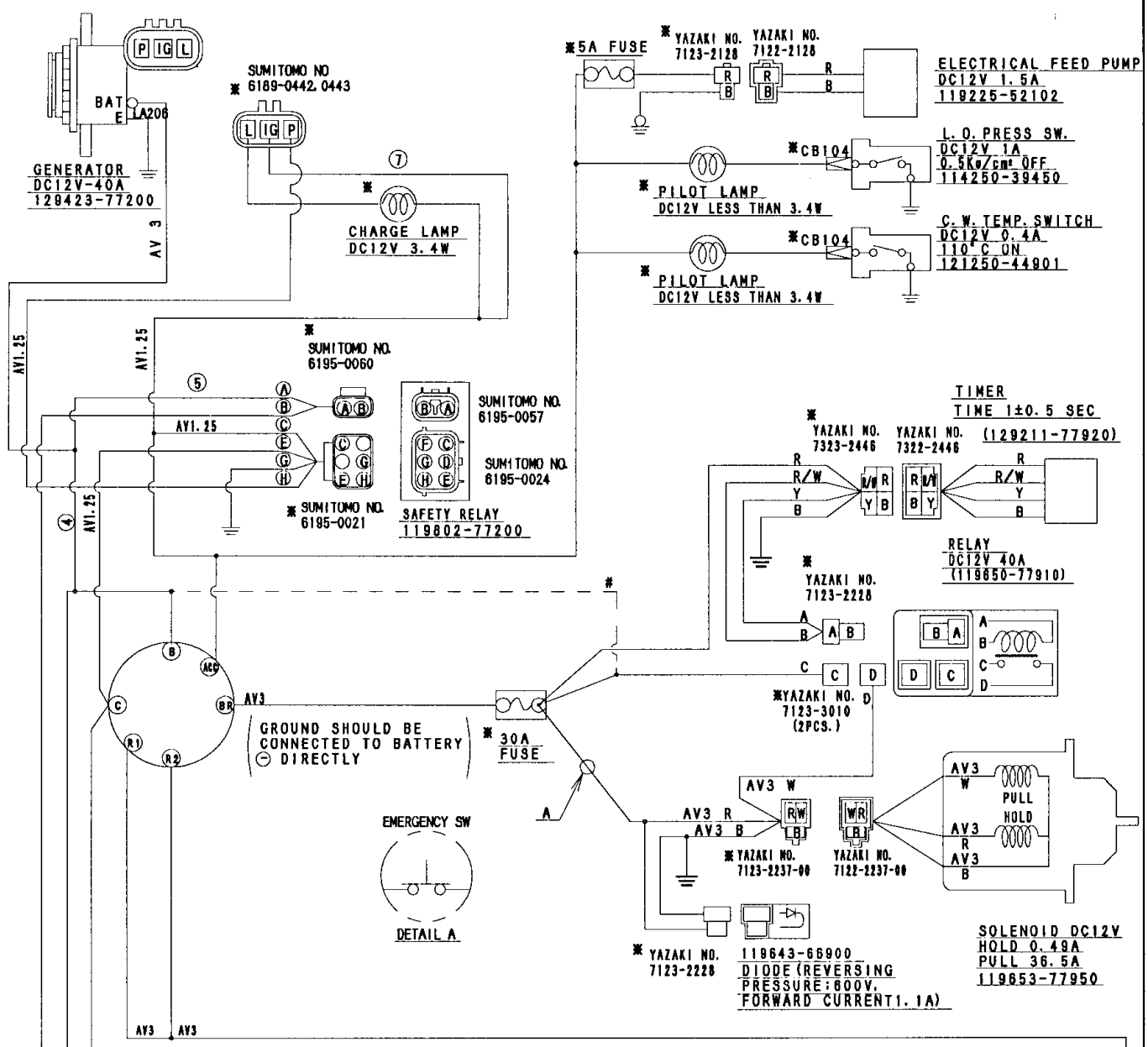

	B	R1	R2	ACC	C	BR
PRE-HEATING	○	○		○		
OFF	○					
ON	○			○		○
START	○		○	○	○	○

KEY SW. DIAGRAM

Model : 3TNV82A
 3TNV84 (T) / 88
 4TNV84 (T) / 88
 SA SERIES
 WIRING DIAGRAM
 Code E3-19802-0010

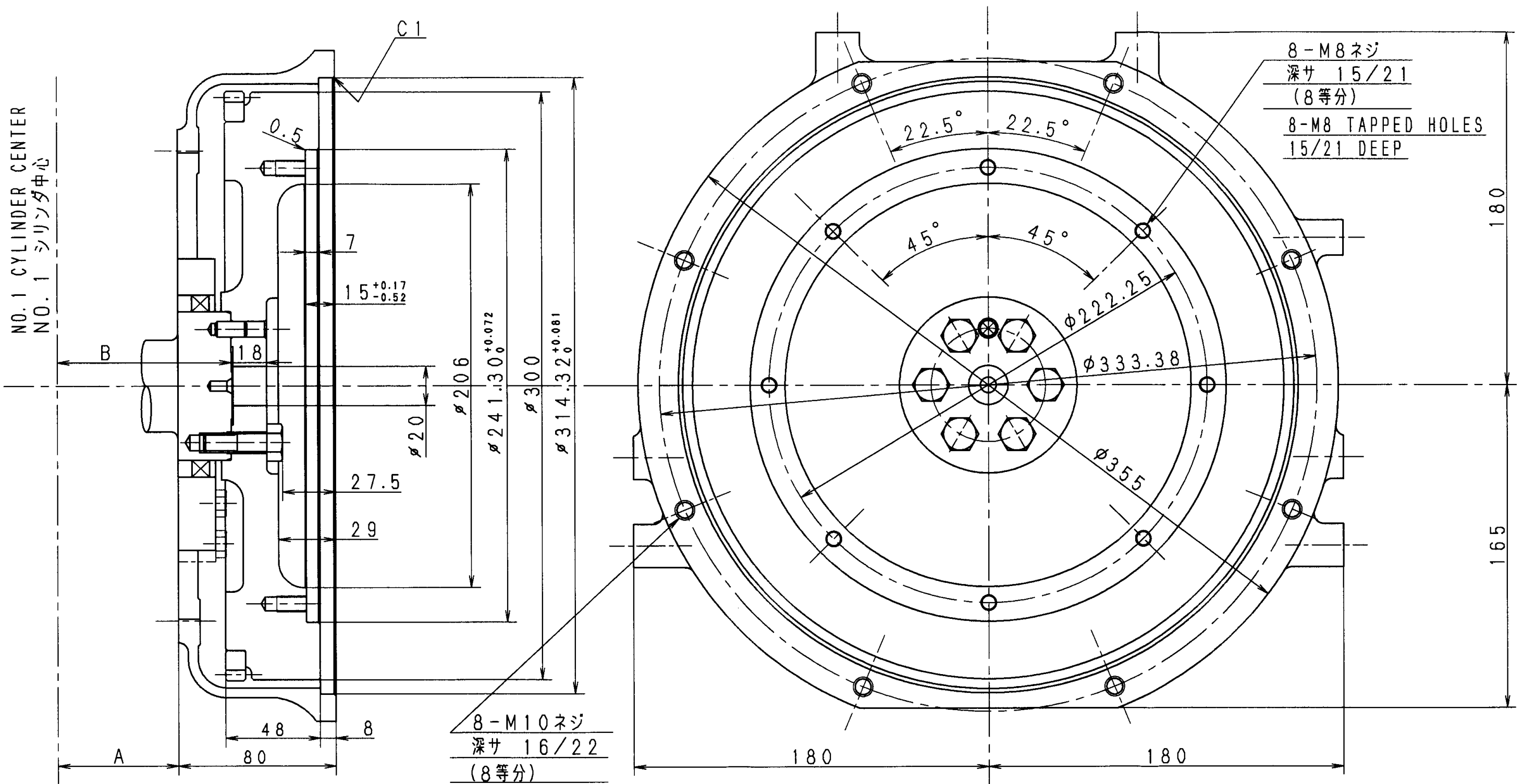

NO.1 CYLINDER CENTER
NO.1 シリンダ中心

8-M8ネジ
深サ 15/21
(8等分)
8-M8 TAPPED HOLES
15/21 DEEP

8-M10ネジ
深サ 16/22
(8等分)

8-M10 TAPPED HOLES
16/22 DEEP

FW:171301-21410
FWH:171301-01600 171340- " 171420- "
129612-01600 171420- " RG:119865-21600

MODEL	DIMENSION A	DIMENSION B	FLYWHEEL HOUSING	FLYWHEEL	RING GEAR
3TNE78A, 82A	56	83.5	129612-01600	171301-21410	119865-21600
3TNE84 (T)	61	88	↑	171340-21410	↑
4TNE84 (T), 88	61	88	↑	171420-21410	↑
3TNV82A	56	83.5	↑	171420-21410	↑
3TNV84T, 88	61	88	↑	171340-21410	↑
4TNV84T, 88	61	88	↑	171420-21410	↑

素材質量 WEIGHT (RAW) (g)	(2)
完成質量 WEIGHT (組立時)	(2)
長 SEC. MANAGER	山田
設計 CHECKED	横井
設計 DESIGNED	野村
機能担当者 SPECIALIST	大塚
年 月 日 DATE	1998 12.14

来歴
CAREER
Rev. 2 (Feb. 20. 2004)
Add TNV DI

水圧試験 HYDRAULIC TEST (MPa)	MPa	エンジン MANAGER	一技長 MANAGER
空圧試験 PNEUMATIC TEST (MPa)	MPa	尺貫 SCALE	1/2
数量 QTY.	1/1	材質 MATERIAL	
名義 NAME	チヨツケツフ ショウサイズ		
	直結部詳細図 (Semi SAE#5)		
	DIMENSIONS OF COUPLI		
YANMAR DIESEL ENGINE CO., LTD.	コード CODE	Rev. 1 Rev. 2	図 NO.
ENGINE DEVELOPMENT DEPT.	23-71301-0011		A3 (B)

Fig. 3TNV82A Engine performance curve

3000rpm

n-BxS:3-82x84

Displacement: 1.331L

Rated power
22.5 kW / 3000 rpm

Silencer	129004-13500	Crank pulley	D=110
Air cleaner	5inch	Fan puley	D=110
CW fan	129335-44740	φ335	PullF

